

# 5kW | Henley Sherwood



## About:

The Sherwood 5 has received an energy rating of A+ and nearly 82% efficiency. It comes with an airwash system which helps to keep the glass clean. It features a tertiary air system. This creates a clean burn system where hot air pushed into the firebox above the normal height of the fire. This allows the excess gas to combust giving a cleaner burn.

## Features:

- 5kW Output
- Efficiency: 81.4%
- Multi-fuel
- Matt Black Steel
- Rear or Top Flue Outlet
- Firebrick Lining
- Height: 559mm
- Width: 382mm
- Depth: 361mm
- Flue: 153mm

## Clearance to Combustibles:

- Rear: 500mm
- Sides: 500mm

## Technical Drawing:

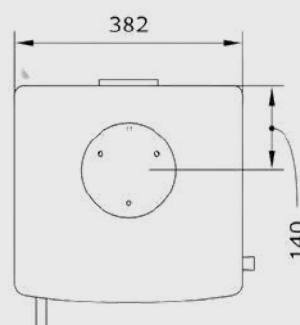
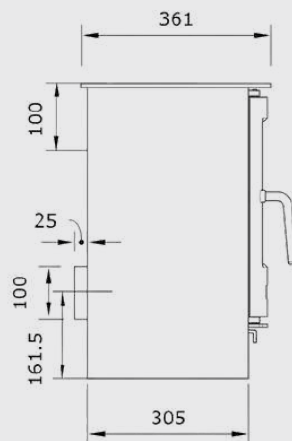
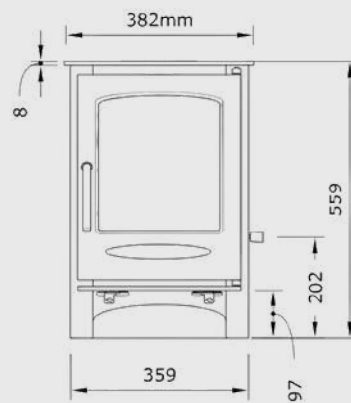

## Certifications:



## Sherwood 5kW:



## Sherwood 5kW With Log Box:



**Sherwood 5kW:**  
RRP: R13 495,00

**Log Box Included:**  
RRP: R17 490,00

# 8kW | Henley Sherwood



## About:

These stoves are external air ready if your house requires this but can be used as a standard stove as well. It comes with an airwash system which helps to keep the glass clean. It features a tertiary air system. This creates a clean burn system where hot air pushed into the firebox above the normal height of the fire. This allows the excess gas to combust giving a cleaner burn.

## Features:

- 8kW Output
- Efficiency: 78.3%
- Multi-fuel
- Matt Black Steel
- Rear or Top Flue Outlet
- Firebrick Lining
- Height: 600mm
- Width: 490mm
- Depth: 380mm
- Flue: 153mm

## Clearance to Combustibles:

- Rear: 700mm
- Sides: 700mm

## Technical Drawing:

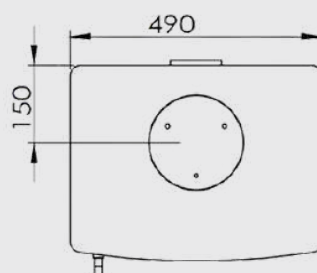
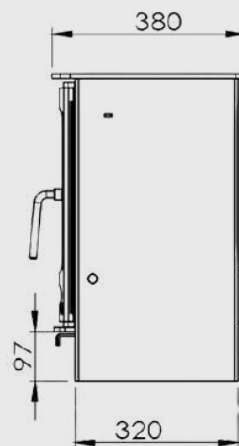
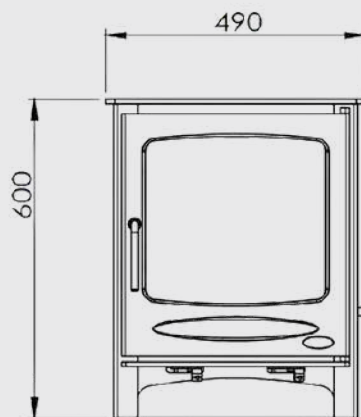

## Certifications:



## Sherwood 8kW:



## Sherwood 8kW With Log Box:



**Sherwood 8kW:**  
RRP: R16 995,00

**Log Box Included:**  
RRP: R21 290,00

# 12kW | Henley Sherwood



## About:

These stoves are external air ready if your house requires this but can be used as a standard stove as well. It comes with an airwash system which helps to keep the glass clean. It features a tertiary air system. This creates a clean burn system where hot air pushed into the firebox above the normal height of the fire. This allows the excess gas to combust giving a cleaner burn.

## Features:

- 12kW Output
- Efficiency: 77.1%
- Multi-fuel
- Matt Black Steel
- Rear or Top Flue Outlet
- Firebrick Lining
- Height: 630mm
- Width: 540mm
- Depth: 390mm
- Flue: 153mm

## Clearance to Combustibles:

- Rear: 900mm
- Sides: 900mm

## Technical Drawing:

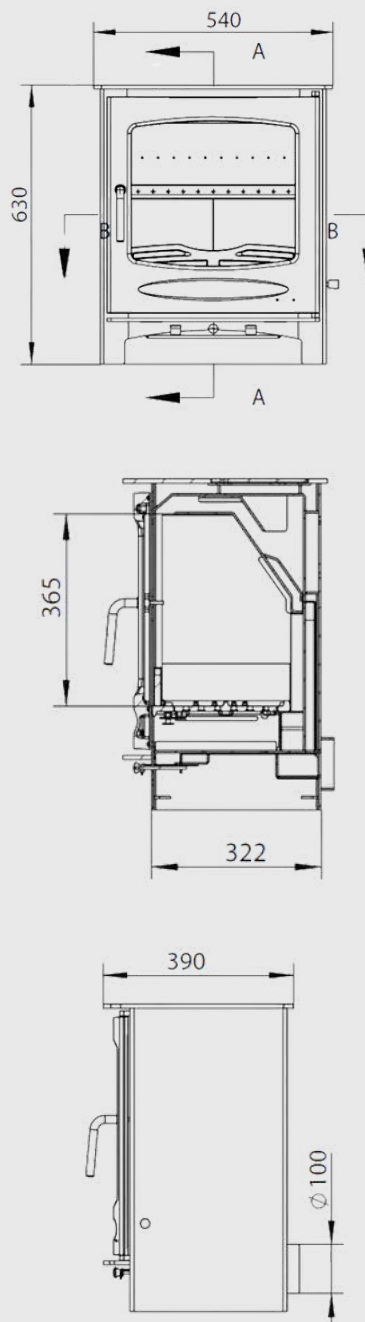

## Certifications:



## Sherwood 12kW:



## Sherwood 12kW With Log Box:



**Sherwood 12kW:**  
RRP: R20 695,00

**Log Box Included:**  
RRP: R25 280,00

# 16kW | Henley Druid



## About:

The Druid 16kW multi-fuel stove is ideal for large living areas. It is constructed from high grade steel with a heavy cast iron door. It also has a double combustion system and cool to touch handle. It boasts an efficiency of 74%. It comes with an air wash system which helps to keep the glass clean. It features a tertiary air system. This creates a clean burn system where hot air pushed into the firebox above the normal height of the fire. This allows the excess gas to combust giving a cleaner burn.

### Features:

- 16kW Output
- Efficiency: 74%
- Multi-fuel
- Matt Black Steel
- Rear or Top Flue Outlet
- Firebrick Lining
- Height: 618mm
- Width: 632mm
- Depth: 436mm
- Flue: 153mm
- Clearance to Combustibles:**
- Rear: 900mm
- Sides: 900mm



**Price:**  
RRP: R25 795,00

## Technical Drawing:

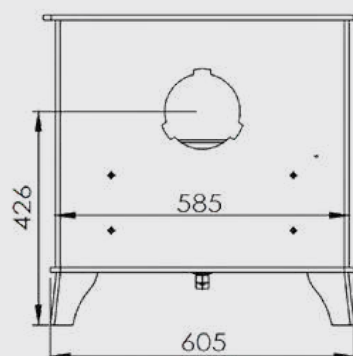
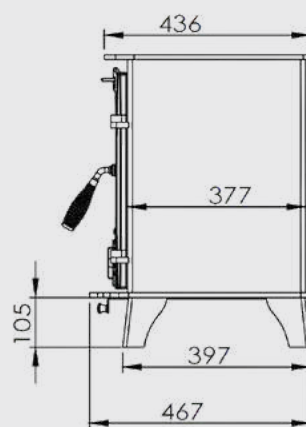
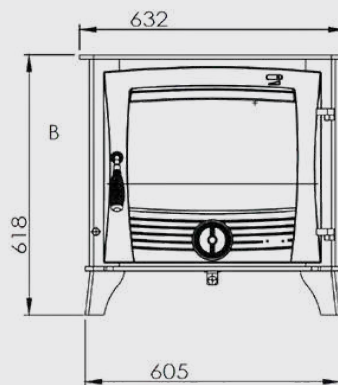

## Certifications:



## Available in Matt Black:



# 14kW | Henley Druid Double Sided



## About:

The Druid 14kW Double sided stove has opening doors on both sides. It is constructed from high grade steel with a heavy cast iron door.

It also has a double combustion system and cool to touch handle.

The stove has an external air facility allowing the air to come directly from outside your building rather than through a vent in the room.

## Features:

14kW Output

Efficiency: 74%

Multi-fuel

Matt Black Steel

Rear or Top Flue Outlet

Firebrick Lining

Height: 628mm

Width: 590mm

Depth: 541mm

Flue: 153mm

### Clearance to Combustibles:

Rear: 900mm

Sides: 900mm

## Technical Drawing:

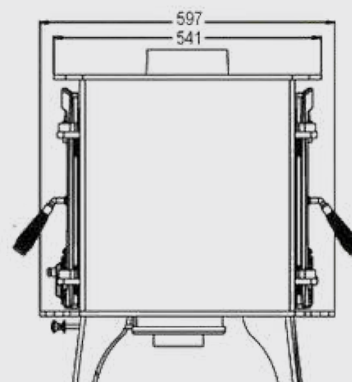
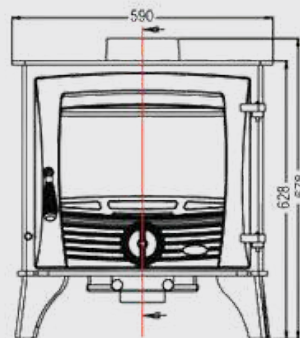
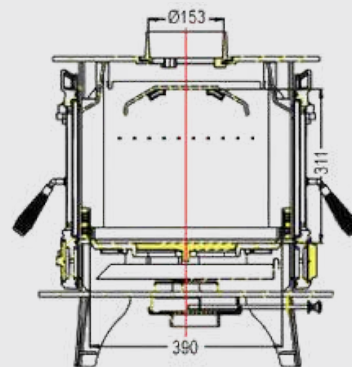

## Certifications:



Available in Matt Black:



Price:

RRP: R28 995,00

# 6.5kW | Henley Elmwood



## About:

Introducing the Elmwood room heater, Eco Design Ready with a 6.5kW heat output. The simplicity of the matt black finish combined with a classic yet modern Victorian design make this model a popular choice for new builds. Ecodesign is a new European-wide program to lower emissions and improve air quality. Ecodesign Ready stoves are the most environmentally friendly stoves available today and benefit from Low particle emissions. 90% better than open fires and 80- 84% better than older stoves.

### Features:

6.5kW Output  
 Efficiency: 79%  
 Fuel: Wood Burning  
 Matt Black Steel  
 Top Flue Outlet  
 Height: 688mm  
 Width: 574mm  
 Depth: 309mm  
 Flue: 125mm

### Clearance to Combustibles:

Rear: 250mm  
 Sides: 250mm



**Price:**  
 RRP: R22 845,00

## Technical Drawing:

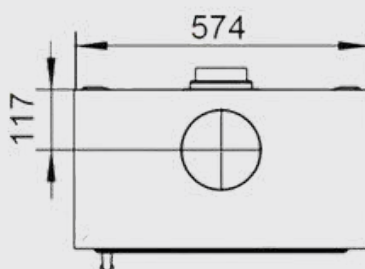
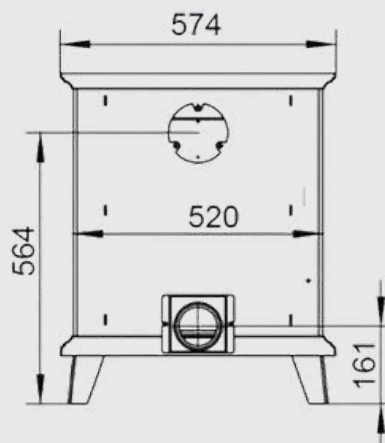
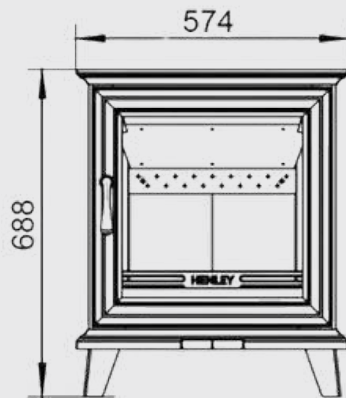

## Certifications:



## Available in Matt Black:

