

CH60 | 60cm Wall Mount Cooker Hood



Features:

- 850m³/h extraction rate
- Noise level: 55-57dBa
- Front push button controls
- 4 Layer aluminium grease filters
- Grease filters are dishwasher safe
- Voltage & Frequency: 220-240/50
- Lighting: 2 x 40W lights
- Unbranded with the EUROair logo for seamless coordination with your kitchen appliances.

Included:

- Charcoal Filters for recirculation
- 1x Flex Pipe: 1m x 125mm diameter
- Butterfly

Product Codes:

- CH60IN:
S/steel Pyramid Extractor
- CH60LIN:
S/steel Linear Extractor
- CH60G:
S/steel Curved Glass Extractor

Technical Drawing:

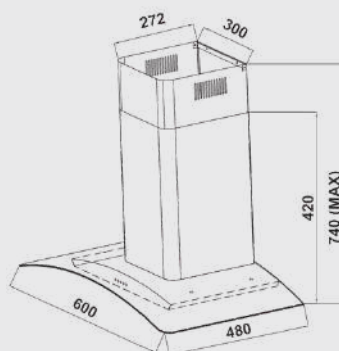
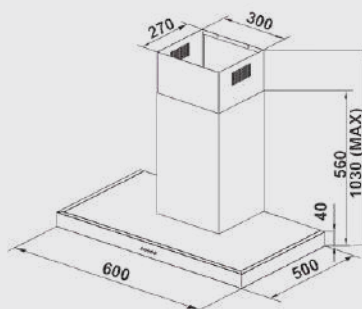
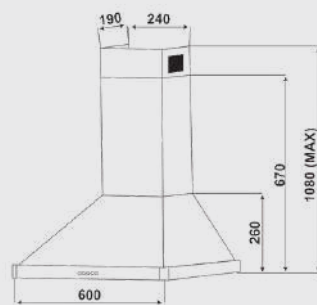

Available Models:



CH60IN & CH60LIN:
RRP. R3995,00

CH60G
RRP. R4495,00

Push Button Controls

1. Press this button to turn the appliance on/off.
2. Press this button to operate in low speed.
3. Press this button to operate in middle speed.
4. Press this button to operate in high speed.
5. Press this button to turn the lamps on.

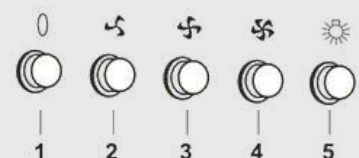

CH90 | 90cm Wall Mount Cooker Hood



Features:

- 850m³/h extraction rate
- Noise level: 55-57dBa
- Front push button controls
- 4 Layer aluminium grease filters
- Grease filters are dishwasher safe
- Lighting: 2 x 20W lights
- Voltage & Frequency: 220-240/50
- Unbranded with the EUROair logo for seamless coordination with your kitchen appliances.

Included:

- Charcoal Filters for recirculation
- 1x Flex Pipe: 1m x 125mm diameter
- Butterfly

Product Codes:

- **CH90IN:**
S/steel Pyramid Extractor
- **CH90LIN:**
S/steel Linear Extractor
- **CH90G:**
S/steel Curved Glass Extractor

Technical Drawing:

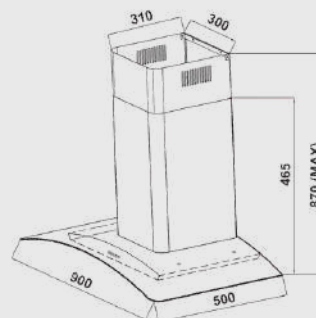
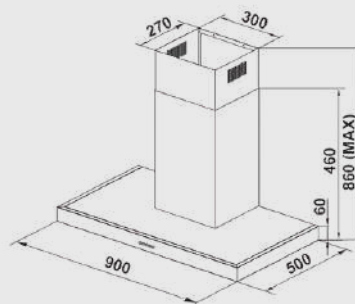
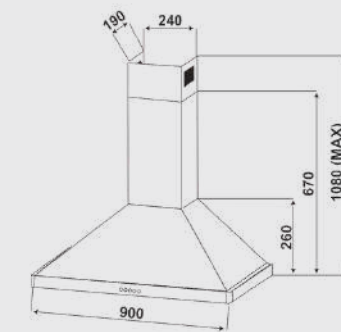

Available Models:



CH90IN & CH90LIN:
RRP. R4795,00

CH90G
RRP. R5695,00

Push Button Controls

1. Press this button to turn the appliance on/off.
2. Press this button to operate in low speed.
3. Press this button to operate in middle speed.
4. Press this button to operate in high speed.
5. Press this button to turn the lamps on.

